

STRENGTH DESIGN OF REINFORCED CONCRETE MASONRY FOUNDATION WALLS

TEK 15-2B
Structural (2004)

Keywords: basements, basement walls, flexural strength, lateral loads, reinforced concrete masonry, strength design, structural properties

INTRODUCTION

Although concrete masonry foundation walls can be constructed without reinforcing steel, reinforcement may be required for walls supporting large soil backfill loads. The strength design provisions found in Chapter 3 of *Building Code Requirements for Masonry Structures* (ref. 1) typically provides increased economy over the allowable stress design method, as thinner walls or larger reinforcing bar spacings often result from a strength design analysis. Strength design criteria are presented in detail in TEK 14-4A, *Strength Design of Concrete Masonry* (ref. 2).

DESIGN LOADS

Soil imparts lateral loads on foundation walls. The load is assumed to increase linearly with depth, resulting in a triangular load distribution on the wall. This lateral soil load is expressed as an equivalent fluid pressure, with units of pounds per square foot per foot of depth (kN/m²/m). For strength design analysis, this lateral soil pressure is increased by multiplying by a load factor, which provides a factor of safety against overload conditions. The maximum moment on the wall depends on the total wall height, the soil backfill height, the wall support conditions, the factored soil load, the existence of any surcharges on the soil and the presence of saturated soils.

Foundation walls also provide support for the structure above the foundation, transferring vertical loads to the footing. Vertical compression counteracts flexural tension, increasing the wall's resistance to flexure. In low-rise construction, these vertical loads are typically small in relation to the compressive strength of the concrete masonry. Vertical load effects are not addressed in this TEK.

DESIGN TABLES

Tables 1 through 4 present reinforcement schedules for 6, 8, 10 and 12-in. (152, 203, 254 and 305-mm) walls, respectively. Additional reinforcement alternatives may be appropriate, and can be verified with an engineering analysis. Walls from 8 to 16 ft (2.4 to 4.9 m) high and soil pressures of 30, 45 and 60 psf/ft (4.7, 7.0, and 9.4 kN/m²/m) are included.

The effective reinforcement depth, d , assumed for the analyses are practical values, taking into account variations in face shell thickness, a range of reinforcing bar sizes, minimum required grout cover and construction tolerances for placing the reinforcement.

The following assumptions also apply to the values in Tables 1 through 4:

- (1) there are no surcharges on the soil adjacent to the wall,
- (2) there are negligible axial loads on the wall,
- (3) the wall is simply supported at top and bottom,
- (4) the wall is grouted at cells containing reinforcement (although solid grouting is acceptable),
- (5) section properties are based on minimum face shell and web thickness requirements of ASTM C90 (ref. 3),
- (6) the specified compressive strength of masonry, f'_m , is 1500 psi (10.3 MPa),
- (7) Grade 60 (413 MPa) reinforcement,
- (8) reinforcement requirements listed account for a soil load factor of 1.6 (ref. 6),
- (9) the maximum width of the compression zone is limited to six times the wall thickness, or a 72 in. (1,829 mm) vertical bar spacing, whichever is smaller,
- (10) reinforcing steel is placed toward the tension (interior) face of the wall (as shown in Figure 1), and
- (11) the soil is well drained to preclude the presence of saturated soil.

Table 1-Reinforcement for 6-inch (152-mm) Concrete Masonry Foundation Walls

Reinforcement required for unfactored equivalent fluid pressure, psf/ft, $d \geq 3.75$ in., bar size and spacing (inches on center)

Wall height, ft	Backfill height, ft	Reinforcement required for unfactored equivalent fluid pressure, psf/ft, $d \geq 3.75$ in., bar size and spacing (inches on center)		
		30 ^(a)	45 ^(b)	60 ^(c)
8	4	No. 3 at 32	No. 3 at 32	No. 3 at 32
	5	No. 3 at 32	No. 4 at 32	No. 4 at 32
	6	No. 4 at 32	No. 5 at 32	No. 5 at 32
	7	No. 4 at 32	No. 5 at 32	No. 6 at 32
	8	No. 5 at 32	No. 6 at 32	No. 6 at 24
8.7	4	No. 3 at 32	No. 3 at 32	No. 3 at 32
	5	No. 3 at 32	No. 4 at 32	No. 4 at 32
	6	No. 4 at 32	No. 5 at 32	No. 5 at 32
	7	No. 5 at 32	No. 6 at 32	No. 6 at 24
	8.7	No. 6 at 32	No. 6 at 24	No. 6 at 16 ^(d)
9.3	4	No. 3 at 32	No. 3 at 32	No. 4 at 32
	5	No. 3 at 32	No. 4 at 32	No. 5 at 32
	6	No. 4 at 32	No. 5 at 32	No. 6 at 32
	7	No. 5 at 32	No. 6 at 32	No. 6 at 24
	9.3	No. 6 at 32	No. 6 at 16 ^(d)	No. 6 at 8 ^(d)
10	4	No. 3 at 32	No. 3 at 32	No. 4 at 32
	5	No. 3 at 32	No. 4 at 32	No. 5 at 32
	6	No. 4 at 32	No. 5 at 32	No. 6 at 32
	7	No. 5 at 32	No. 6 at 32	No. 6 at 24
	8	No. 6 at 32	No. 6 at 24	No. 6 at 16 ^(d)
	10	No. 6 at 24	No. 6 at 8 ^(d)	(e)

Table 2-Reinforcement for 8-inch (203-mm) Concrete Masonry Foundation Walls

Reinforcement required for unfactored equivalent fluid pressure, psf/ft, $d \geq 5$ in., bar size and spacing (inches on center)

Wall height, ft	Backfill height, ft	Reinforcement required for unfactored equivalent fluid pressure, psf/ft, $d \geq 5$ in., bar size and spacing (inches on center)		
		30 ^(a)	45 ^(b)	60 ^(c)
8	4	No. 3 at 48	No. 3 at 48	No. 4 at 48
	5	No. 3 at 48	No. 4 at 48	No. 5 at 48
	6	No. 4 at 48	No. 5 at 48	No. 6 at 48
	7	No. 5 at 48	No. 6 at 48	No. 7 at 48
	8	No. 5 at 48	No. 7 at 48	No. 7 at 48
8.7	4	No. 3 at 48	No. 3 at 48	No. 4 at 48
	5	No. 3 at 48	No. 4 at 48	No. 5 at 48
	6	No. 4 at 48	No. 5 at 48	No. 6 at 48
	7	No. 5 at 48	No. 6 at 48	No. 7 at 48
	8.7	No. 6 at 48	No. 7 at 48	No. 8 at 48
9.3	4	No. 3 at 48	No. 3 at 48	No. 4 at 48
	5	No. 4 at 48	No. 4 at 48	No. 5 at 48
	6	No. 4 at 48	No. 5 at 48	No. 6 at 48
	7	No. 5 at 48	No. 6 at 48	No. 7 at 48
	9.3	No. 7 at 48	No. 8 at 48	No. 8 at 32 ^(d)
10	4	No. 3 at 48	No. 3 at 48	No. 4 at 48
	5	No. 4 at 48	No. 4 at 48	No. 5 at 48
	6	No. 4 at 48	No. 5 at 48	No. 6 at 48
	7	No. 5 at 48	No. 6 at 48	No. 7 at 48
	8	No. 6 at 48	No. 7 at 48	No. 8 at 48
	10	No. 7 at 48	No. 8 at 40	No. 8 at 24
12	4	No. 3 at 48	No. 3 at 48	No. 4 at 48
	5	No. 4 at 48	No. 4 at 48	No. 5 at 48
	6	No. 4 at 48	No. 5 at 48	No. 6 at 48
	7	No. 5 at 48	No. 7 at 48	No. 8 at 48
	8	No. 6 at 48	No. 8 at 48	No. 8 at 40
	9	No. 7 at 48	No. 8 at 40	No. 8 at 32 ^(d)
	10	No. 8 at 48	No. 8 at 32 ^(d)	No. 8 at 16 ^(d)
	11	No. 8 at 40	No. 8 at 24 ^(d)	No. 8 at 8 ^(d)
	12	No. 8 at 32 ^(d)	No. 8 at 16 ^(d)	No. 8 at 8 ^(d)

Notes to Tables 1 - 4:

- (a) granular soil backfill
- (b) drained silty sand or silty clay backfill
- (c) clay soil backfill
- (d) exceeds maximum permitted tensile reinforcement (ref. 2)
- (e) can't be done with No. 6 (M# 19) bars
- (f) metric equivalents: in. x 25.4 = mm; No. 3 = M# 10; No. 4 = M# 13; No. 5 = M# 16; No. 6 = M# 19; No. 7 = M# 22; No. 8 = M# 25; No. 9 = M# 29

DESIGN EXAMPLE

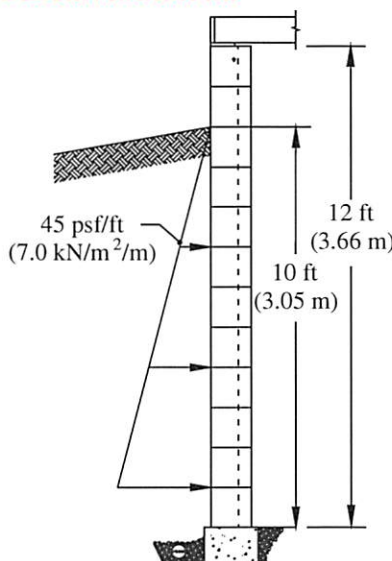

Wall: 12-in.(305mm)thick concrete masonry foundation wall, 12 ft(3.66 m) high

Soil: equivalent fluid pressure is 45 psf/ft (7.0 kN/m²/m)(excluding soil load factors), 10 ft (3.05 m) backfill height

Using Table 4, the wall can be adequately reinforced using No. 9 bars at 72 in. o.c. (M# 29 at 1,829mm).

CONSTRUCTION ISSUES

This section discusses those issues which directly relate to structural design assumptions. See TEK 3-11, *Concrete Masonry Basement Wall Construction* and TEK 5-3A, *Concrete Masonry Foundation Wall Details* (refs. 4,5) for more complete information on building concrete masonry foundation walls.

Figure 1 illustrates wall support conditions, drainage and protection from water. Before backfilling, the floor diaphragm must be in place, or the wall must be properly braced to resist the soil load. Ideally, the backfill should be free-draining granular material, free from expansive soils or other deleterious materials.

The assumption that there are no surcharges on the soil means that heavy equipment should not be operated directly adjacent to any basement wall system. In addition, the backfill materials should be placed and compacted in several lifts. Care should be taken when placing backfill materials to prevent damaging the drainage, waterproofing or exterior insulation systems.

Wall height, ft	Backfill height, ft	Reinforcement required for unfactored equivalent fluid pressure, psf/ft, $d \geq 7$ in., bar size and spacing (inches on center)		
		30 ^(a)	45 ^(b)	60 ^(c)
8	4	No. 3 at 56	No. 3 at 56	No. 3 at 56
	5	No. 3 at 56	No. 4 at 56	No. 4 at 56
	6	No. 4 at 56	No. 4 at 56	No. 5 at 56
	7	No. 4 at 56	No. 5 at 56	No. 6 at 56
	8	No. 5 at 56	No. 6 at 56	No. 7 at 56
10	4	No. 3 at 56	No. 3 at 56	No. 3 at 56
	5	No. 3 at 56	No. 4 at 56	No. 4 at 56
	6	No. 4 at 56	No. 5 at 56	No. 5 at 56
	7	No. 5 at 56	No. 6 at 56	No. 6 at 56
	8	No. 5 at 56	No. 7 at 56	No. 7 at 56
	9	No. 6 at 56	No. 7 at 56	No. 8 at 56
12	4	No. 3 at 56	No. 3 at 56	No. 4 at 56
	5	No. 3 at 56	No. 4 at 56	No. 5 at 56
	6	No. 4 at 56	No. 5 at 56	No. 6 at 56
	7	No. 5 at 56	No. 6 at 56	No. 7 at 56
	8	No. 6 at 56	No. 7 at 56	No. 8 at 56
	9	No. 7 at 56	No. 8 at 56	No. 9 at 56
	10	No. 7 at 56	No. 9 at 56	No. 9 at 40
14	4	No. 3 at 56	No. 3 at 56	No. 4 at 56
	5	No. 3 at 56	No. 4 at 56	No. 5 at 56
	6	No. 4 at 56	No. 5 at 56	No. 6 at 56
	7	No. 5 at 56	No. 6 at 56	No. 7 at 56
	8	No. 6 at 56	No. 7 at 56	No. 8 at 56
	9	No. 7 at 56	No. 8 at 56	No. 9 at 48
	10	No. 8 at 56	No. 9 at 56	No. 9 at 40
	11	No. 9 at 56	No. 9 at 40	No. 9 at 32 ^(d)
	12	No. 9 at 56	No. 9 at 32 ^(d)	No. 9 at 24 ^(d)
	13	No. 9 at 40	No. 9 at 24 ^(d)	No. 9 at 16 ^(d)
14	No. 9 at 40	No. 9 at 16 ^(d)	No. 9 at 8 ^(d)	

Wall height, ft	Backfill height, ft	Reinforcement required for unfactored equivalent fluid pressure, psf/ft, $d \geq 9$ in., bar size and spacing (inches on center)			
		30 ^(a)	45 ^(b)	60 ^(c)	
12	4	No. 3 at 72	No. 3 at 72	No. 4 at 72	
	5	No. 3 at 72	No. 4 at 72	No. 5 at 72	
	6	No. 4 at 72	No. 5 at 72	No. 6 at 72	
	7	No. 5 at 72	No. 6 at 72	No. 7 at 72	
	8	No. 6 at 72	No. 7 at 72	No. 8 at 72	
	9	No. 6 at 72	No. 8 at 72	No. 9 at 72	
	10	No. 7 at 72	No. 9 at 72	No. 9 at 56	
	11	No. 8 at 72	No. 9 at 64	No. 9 at 48	
	12	No. 9 at 72	No. 9 at 56	No. 9 at 40	
	14	4	No. 3 at 72	No. 3 at 72	No. 4 at 72
		5	No. 3 at 72	No. 4 at 72	No. 5 at 72
		6	No. 4 at 72	No. 5 at 72	No. 6 at 72
7		No. 5 at 72	No. 6 at 72	No. 7 at 72	
8		No. 6 at 72	No. 7 at 72	No. 8 at 72	
9		No. 7 at 72	No. 8 at 72	No. 9 at 72	
10		No. 8 at 72	No. 9 at 72	No. 9 at 48	
11		No. 8 at 72	No. 9 at 56	No. 9 at 40	
12		No. 9 at 72	No. 9 at 48	No. 9 at 32	
13		No. 9 at 56	No. 9 at 40	No. 9 at 24 ^(d)	
14		No. 9 at 48	No. 9 at 32	No. 9 at 24 ^(d)	
16		4	No. 3 at 72	No. 3 at 72	No. 4 at 72
		5	No. 4 at 72	No. 4 at 72	No. 5 at 72
		6	No. 4 at 72	No. 5 at 72	No. 6 at 72
	7	No. 5 at 72	No. 6 at 72	No. 7 at 72	
	8	No. 6 at 72	No. 7 at 72	No. 9 at 72	
	9	No. 7 at 72	No. 9 at 72	No. 9 at 64	
	10	No. 8 at 72	No. 9 at 64	No. 9 at 48	
	11	No. 9 at 72	No. 9 at 48	No. 9 at 32	
	12	No. 9 at 64	No. 9 at 40	No. 9 at 32	
	13	No. 9 at 48	No. 9 at 32	No. 9 at 24 ^(d)	
	14	No. 9 at 40	No. 9 at 24 ^(d)	No. 9 at 16 ^(d)	
	15	No. 9 at 40	No. 9 at 24 ^(d)	No. 9 at 16 ^(d)	
	16	No. 9 at 32	No. 9 at 16 ^(d)	No. 9 at 8 ^(d)	

REFERENCES

1. *Building Code Requirements for Masonry Structures*, ACI 530-02/ASCE 5-02/TMS 402-02. Reported by the Masonry Standards Joint Committee, 2002.
2. *Strength Design of Concrete Masonry*, TEK 14-4A. National Concrete Masonry Association, 2002.
3. *Standard Specification for Loadbearing Concrete Masonry Units*, ASTM C 90-03. ASTM International, 2003.
4. *Concrete Masonry Basement Wall Construction*, TEK 3-11. National Concrete Masonry Association, 2001.
5. *Concrete Masonry Foundation Wall Details*, TEK 5-3A. National Concrete Masonry Association, 2003.
6. *Minimum Design Loads for Buildings and Other Structures*, ASCE 7-02. American Society of Civil Engineers, 2002.

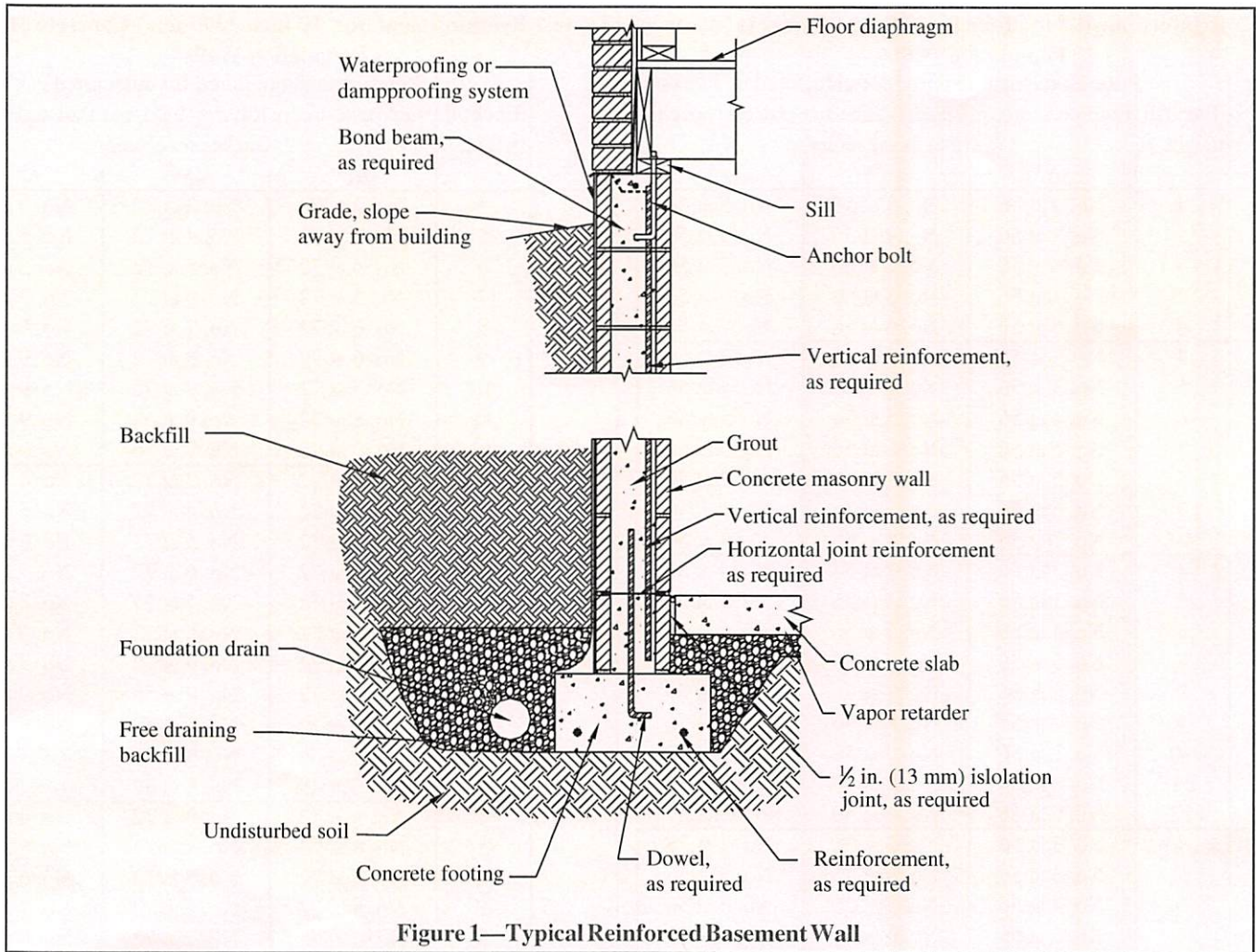

Disclaimer: Although care has been taken to ensure the enclosed information is as accurate and complete as possible, NCMA does not assume responsibility for errors or omissions resulting from the use of this TEK.